

# TRANSPORT EQUIPMENT FOR WIND POWER PLANTS







## **GOLDHOFER – THE ORIGINAL FOR TRANSPORTING WIND POWER PLANTS**

Goldhofer is one of the world market leaders for specialized transport equipment in the field of general and heavy-duty road haulage and oversized cargo transportation. Thanks to a full and proven range of products, including trailers, semitrailers, self-propelled modular vehicles and aircraft tow tractors, Goldhofer meets an extremely wide variety of needs in every transport situation.

We are the people to turn to for the transport of extremely long and heavy loads for on- and offshore wind power plants. In this field, Goldhofer is your expert for the most suitable and economical vehicle configuration. Thanks to our proven vehicle technology, perfect all-round service, extensive know-how and professional project engineering, customers can rely 100% on Goldhofer in every situation.

# TOWER SEGMENTS



# RA 2 TOWER ADAPTER FOR TOWER SEGMENTS UP TO 100 T

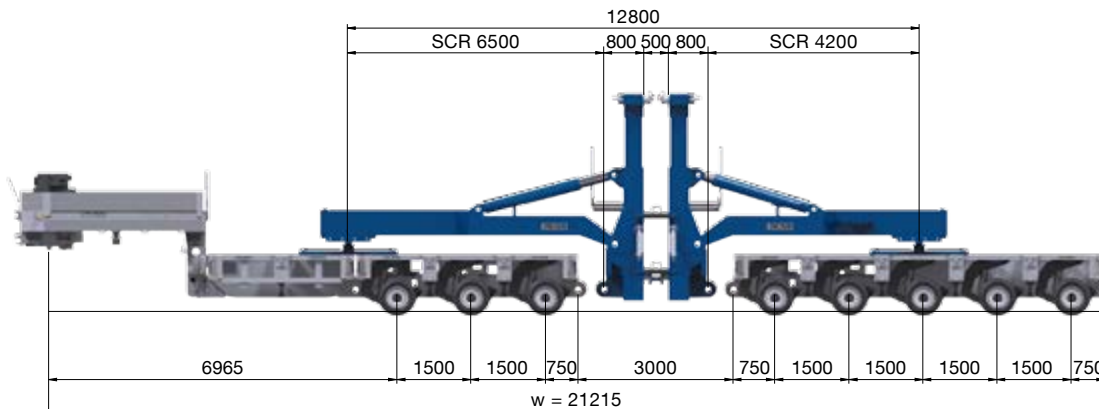

## FEATURES:

- ✓ Payload: 2 x 50,000 kg
- ✓ Tower diameter, inner flange: 1,665–4,965 mm
- ✓ Tower diameter, outer flange: 2,070–5,280 mm
- ✓ Combinable with bogie modules (rigid coupling or free-turning)
- ✓ Combinable with dolly trailers (free-turning only)
- ✓ Control panel for the hydraulics
- ✓ Aluminum working platform with ladder

## OPTIONS:

- Removable extension for tube diameters of up to 6,000 mm
- Free-turning units with steering actuation (for direct mounting on fifth-wheel coupling on tractor/dolly)
- Free-turning units without steering actuation (for combination with long-load turntable bolsters)

## DEADWEIGHTS:

- RA 2 per adapter: approx. 5,750 kg
- FTD with SCR of 4,200 mm: approx. 3,500 kg
- FTD with SCR of 6,500 mm: approx. 4,800 kg

## TECHNICAL DATA:

### MAX. PAYLOAD PER ADAPTER PAIR (RIGID CONNECTION/CENTRAL CENTER OF GRAVITY)

- STHP 8 (3+5): approx. 100,000 kg
- STHP 10 (4+6): approx. 88,000 kg

## TECHNICAL DATA:

### MAX. PAYLOAD PER ADAPTER PAIR (IN COMBINATION WITH FREE-TURNING DEVICE/CENTRAL CENTER OF GRAVITY)

- SCR 4,200 mm: approx. 96,000 kg
- SCR 6,500 mm: approx. 67,000 kg

FTD = Free-turning device  
SCR = Swing clearance radius









# RA 4

## TOWER ADAPTER FOR TOWER SEGMENTS UP TO 180 T

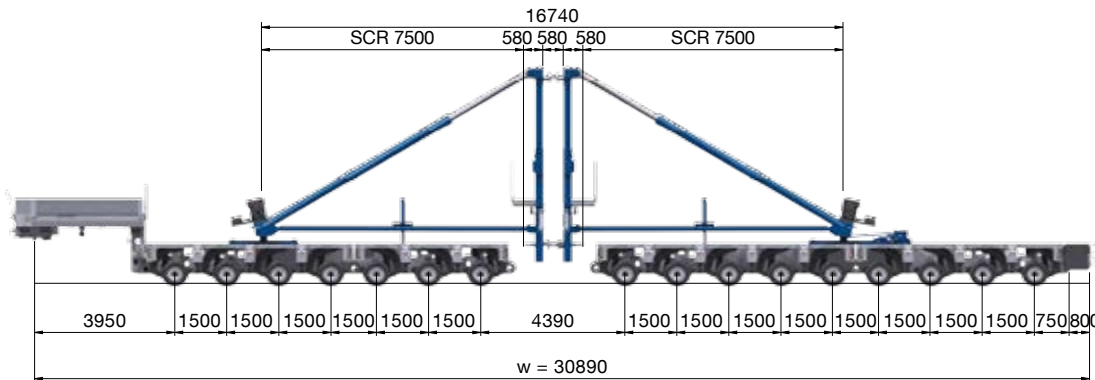

### FEATURES:

- ✓ Payload: 2 x 90,000 kg
- ✓ Tower diameter, inner flange: 3,000–6,000 mm
- ✓ Combinable with bogie modules (free-turning only, no rigid coupling)
- ✓ Support cylinder to bogie with 600 mm stroke
- ✓ Hydraulic lateral adjustment for easier positioning on loading
- ✓ Control panel for the hydraulics
- ✓ Aluminum working platform with ladder

### OPTIONS:

- Power packs for independent hydraulics supply (integrated oil tanks)
- Clamping device for towers with external flange: 2,800–5,800 mm

### DEADWEIGHT PER ADAPTER BY SWING CLEARANCE RADIUS:

- SCR 7,500 mm: 10,000 kg

### TECHNICAL DATA:

#### STHP/SL-L 16 (7+9) + RA 4 (CENTRAL CENTER OF GRAVITY)

- Fifth-wheel load: 22,000 kg
- Axle load: 16 x 12,000 kg
- Total weight: 214,000 kg
- Deadweight: 73,600 kg
- Payload: 140,400 kg

SCR = Swing clearance radius



# STZ-VL/STZ-VP/MPA-V DROP-DECK SEMITRAILERS

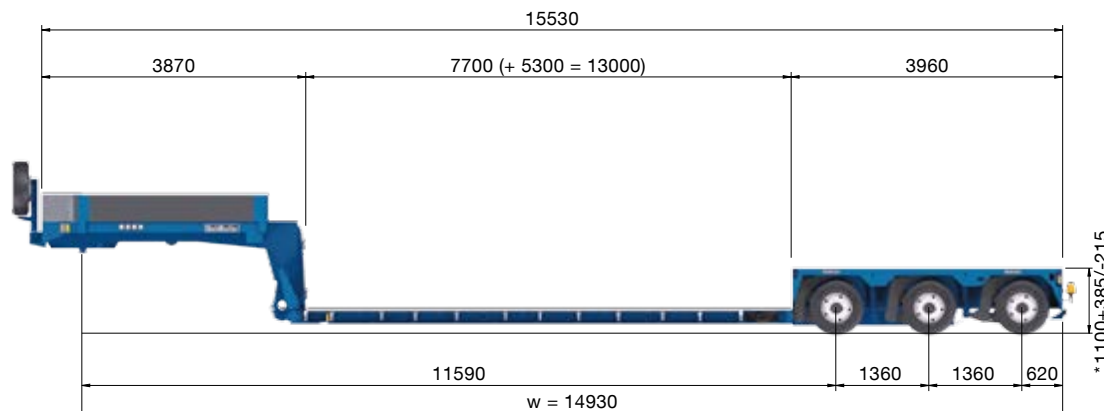

## FEATURES:

- ✓ Lift- and lowerable gooseneck, front-end loading
- ✓ Swing clearance radius: 2,500–3,400 mm
- ✓ Drop deck height: 220 mm
- ✓ Loading height: 370 mm at 150 mm ground clearance
- ✓ Bogies with pneumatic or pendular suspension or MPA axle technology
- ✓ Axle stroke: 200–600 mm/steering angle: 45–60°
- ✓ Excavator recess on bogie, full-length

## OPTIONS:

- Aluminum side walls
- Premium stowage box
- Flat-bed extension joint
- Drop-in deck
- etc.

## TECHNICAL DATA E.G. STZ-VP 3 A:

- Fifth-wheel load: 22,000 kg
- Axle load: 3 x 12,000 kg
- Total weight: 58,000 kg
- Deadweight: approx. 18,800 kg
- Payload: approx. 39,200 kg



\* loaded

# OFF-SHORE WIND TURBINE COMPONENTS



# THP/SL AND PST/SL MODULAR HEAVY-DUTY SYSTEMS

## THP/SL:

- Width: 3,000 mm
- Axle load: 45 t at 1 km/h
- Tires: 215/75 R 17.5 twin tires
- Loading height: 1,175 +/- 300 mm

## PST/SL:

- Width: 3,000 mm
- Axle load: 45 t at 1 km/h
- Tires: 215/75 R 17.5 twin tires
- Loading height: 1,175 +/- 300 mm
- Tractive force: 160 kN per driven axle line



## FEATURES:

- ✓ Non-driven or hydrostatically driven modular heavy-duty systems
- ✓ Mechanical steering, 55° steering angle
- ✓ Sturdy frame with high torsional resistance and closed loading platform for concentrated loads
- ✓ High maximum permissible bending moment
- ✓ Excellent stability
- ✓ Vehicles freely combinable and positionable

## OPTIONS:

- Power packs with 210/280/490 hp
- Combinable with rotor blade adapter
- Radio remote control
- Combinable with THP modules
- etc.

## TECHNICAL DATA E.G. PST/SL 6:

- |                 |         |            |
|-----------------|---------|------------|
| - Speed:        |         | 5 km/h     |
| - Axle load:    | 6 x     | 36,600 kg  |
| - Total weight: |         | 219,600 kg |
| - Deadweight:   | approx. | 27,100 kg  |
| - Payload:      | approx. | 192,500 kg |



# NACELLES/HUBS



Photo: Klaas Eissens

# PST/SL-E AND PST/ES-E MODULAR HEAVY-DUTY SYSTEMS

## PST/SL-E:

- Width: 3,000 mm
- Axle load: 45 t at 1 km/h
- Tires: 215/75 R 17.5 twin tires
- Loading height: 1,220 +/- 300 mm
- Tractive force: 160 kN per driven axle line

## PST/ES-E (285):

- Width: 2,430 mm
- Axle load: 40 t at 0.4 km/h
- Tires: 285/70 R 19.5 single tires
- Loading height: 1,500 +/- 325 mm
- Tractive force: 160 kN per driven axle line

## PST/ES-E (315):

- Width: 2,430 mm
- Axle load: 45 t at 1 km/h
- Tires: 315/60 R 22.5 single tires
- Loading height: 1,500 +/- 350 mm
- Tractive force: 160 kN per driven axle line

## PST/ES-E (385):

- Width: 2,430 mm
- Axle load: 60 t at 1 km/h
- Tires: 385/55 R 22.5 single tires
- Loading height: 1,515 +/- 350 mm
- Tractive force: 160 kN per driven axle line



## FEATURES:

- ✓ Self-propelled, hydrostatic drive
- ✓ Electronic multiway steering, +/-135° steering angle
- ✓ Sturdy frame with high torsional resistance and closed loading platform for concentrated loads
- ✓ High permissible bending moment
- ✓ Excellent stability
- ✓ Vehicles freely combinable and positionable

## OPTIONS:

- Power packs with 210/280/490 hp
- PST/SL-E combinable with rotor blade adapter
- Radio remote control
- PST/SL-E combinable with all THP modules

## TECHNICAL DATA E.G. PST/SL-E 10 P (1+1):

- Speed:		5 km/h
- Axle load:	20 x	36,600 kg
- Total weight:		732,000 kg
- Deadweight:	approx.	95,000 kg
- Payload:	approx.	637,000 kg



# ROTOR BLADES





# SPZ-GL AAA/SPZ-L AAA

## EUROPE FLATBED

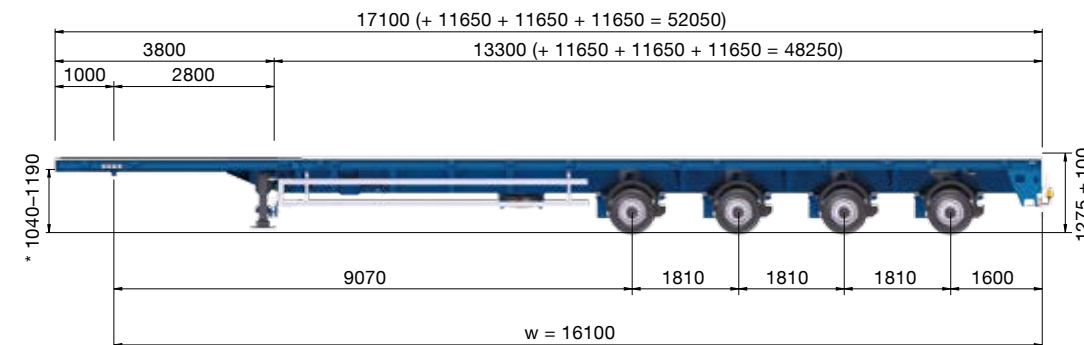
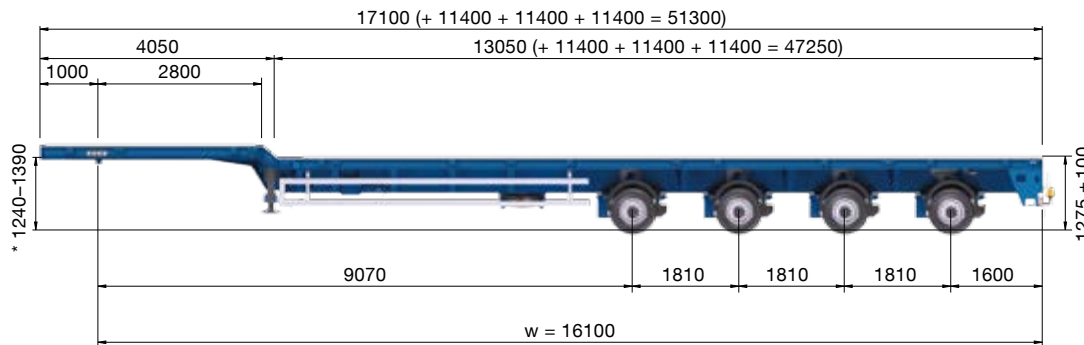

### FEATURES:

- ✓ Triple telescopic flatbed semi-trailer
- ✓ Extendable to 51,300 mm
- ✓ Suitable for practically all standard rotor blades
- ✓ Full lashing system
- ✓ Folding support legs and separate switch for shifting deadweight to the 1st and 2nd axles for easier telescoping

### OPTIONS:

- Bolt-on steel front wall
- Stowage box under the loading platform
- Lift axle
- Special adapter for VESTAS V 112 rotor blade

### TECHNICAL DATA:

(VARY ACCORDING TO NATIONAL SPECIFICATIONS)

	SPZ-GL 3	SPZ-GL 4	SPZ-L 4
- FWL:	26,000 kg	26,000 kg	26,000 kg
- AL:	3 x 12,000 kg	4 x 12,000 kg	4 x 12,000 kg
- TW:	62,000 kg	74,000 kg	74,000 kg
- DW:	approx. 17,000 kg	18,000 kg	18,200 kg
- PL:	approx. 45,000 kg	56,000 kg	55,800 kg



\* loaded



# SPZ-GP 3 AAA/SPZ-P 3 AAA FLATBED WITH PENDULAR AXLES

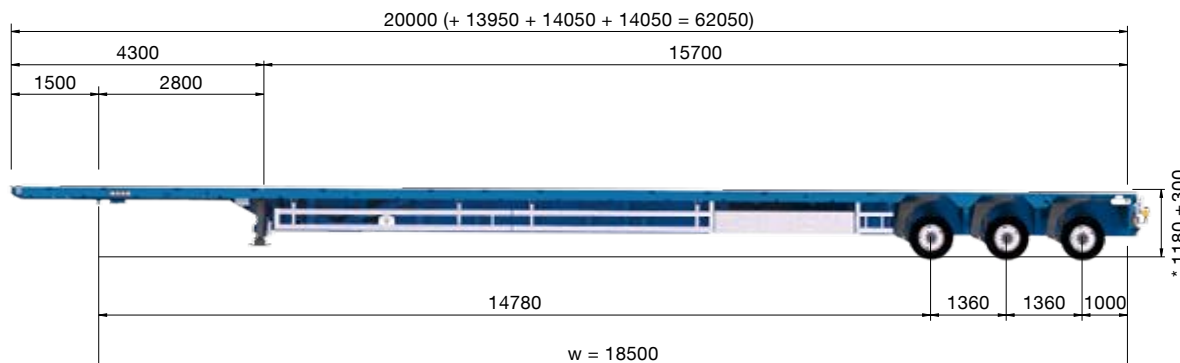
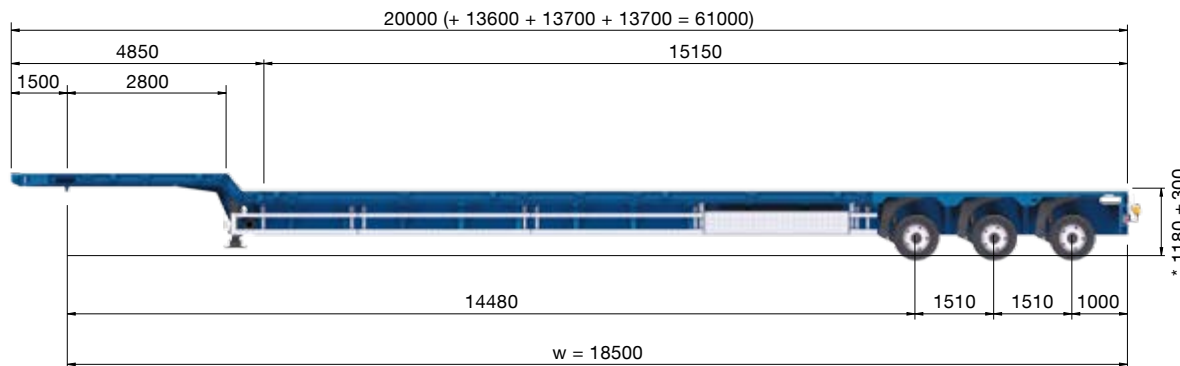

## FEATURES:

- ✓ Triple telescopic flatbed semi-trailer with pendular axle technology
- ✓ Axle stroke: 600 mm/steering angle: 60°
- ✓ Extendable to 62,000 mm
- ✓ Suitable for very long rotor blades
- ✓ Full lashing system
- ✓ Hydraulic support legs for easier telescoping

## OPTIONS:

- Bolt-on steel front wall
- Stake pocket rails
- Stowage box under the loading platform
- Special adapter and roller table for VESTAS V 112 rotor blade

## TECHNICAL DATA:

(VARY ACCORDING TO NATIONAL SPECIFICATIONS)

	SPZ-GP 3		SPZ-P 3	
- Fifth-wheel load:		26,000 kg		26,000 kg
- Axle load:	3 x	12,000 kg	3 x	12,000 kg
- Total weight:		62,000 kg		62,000 kg
- Deadweight:	approx.	24,300 kg	approx.	24,400 kg
- Payload:	approx.	37,700 kg	approx.	37,600 kg



\* loaded



80

Achtung  
Anhängers  
schert aus

LWL MB 538

Goldhofer

# SPZ-GP 3 AAAA SUPER LIFT

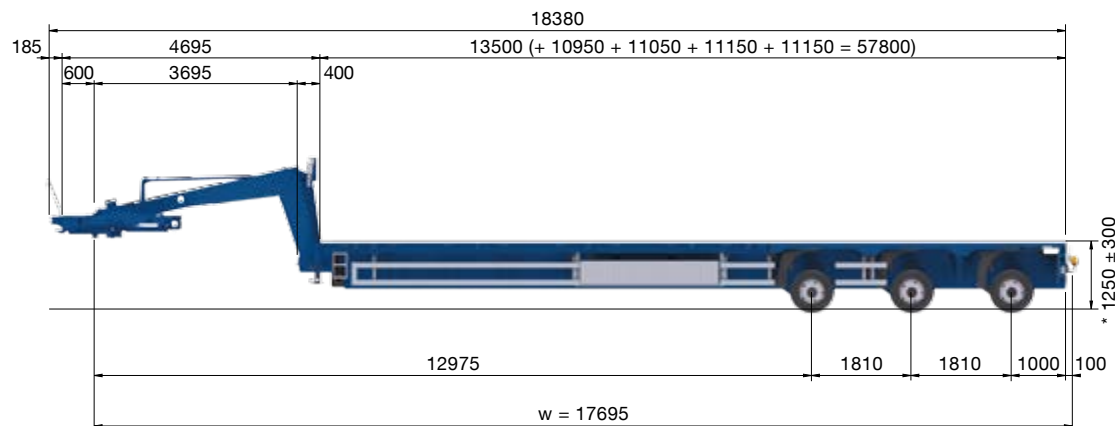

## FEATURES:

- ✓ 4-fold telescopic flatbed semi-trailer with pendular axle technology
- ✓ Hydraulically lift- and lowerable gooseneck for ground clearing 0–1,500 mm below the central tube
- ✓ Swing clearance radius: 3,400 mm for 5-axle tractor or 4-axle tractor with dolly
- ✓ Axle stroke: 600 mm/steering angle: 60°
- ✓ Loading platform: extendable to 57,800 mm
- ✓ Suitable for very long rotor blades
- ✓ Full lashing system
- ✓ Hydraulic support legs for easier telescoping

## OPTIONS:

- Stowage box under the loading platform
- Insertable cross beam
- Special adapter and roller table for VESTAS V 112 rotor blade

## TECHNICAL DATA:

### (VARY ACCORDING TO NATIONAL SPECIFICATIONS)

- Fifth-wheel load: 35,000 kg
- Axle load: 3 x 12,000 kg
- Total weight: 71,000 kg
- Deadweight: approx. 29,800 kg
- Payload: approx. 41,200 kg



\* loaded



# FTV

## ROTOR BLADE TRANSPORT DEVICE FOR MODULAR HEAVY-DUTY SYSTEMS

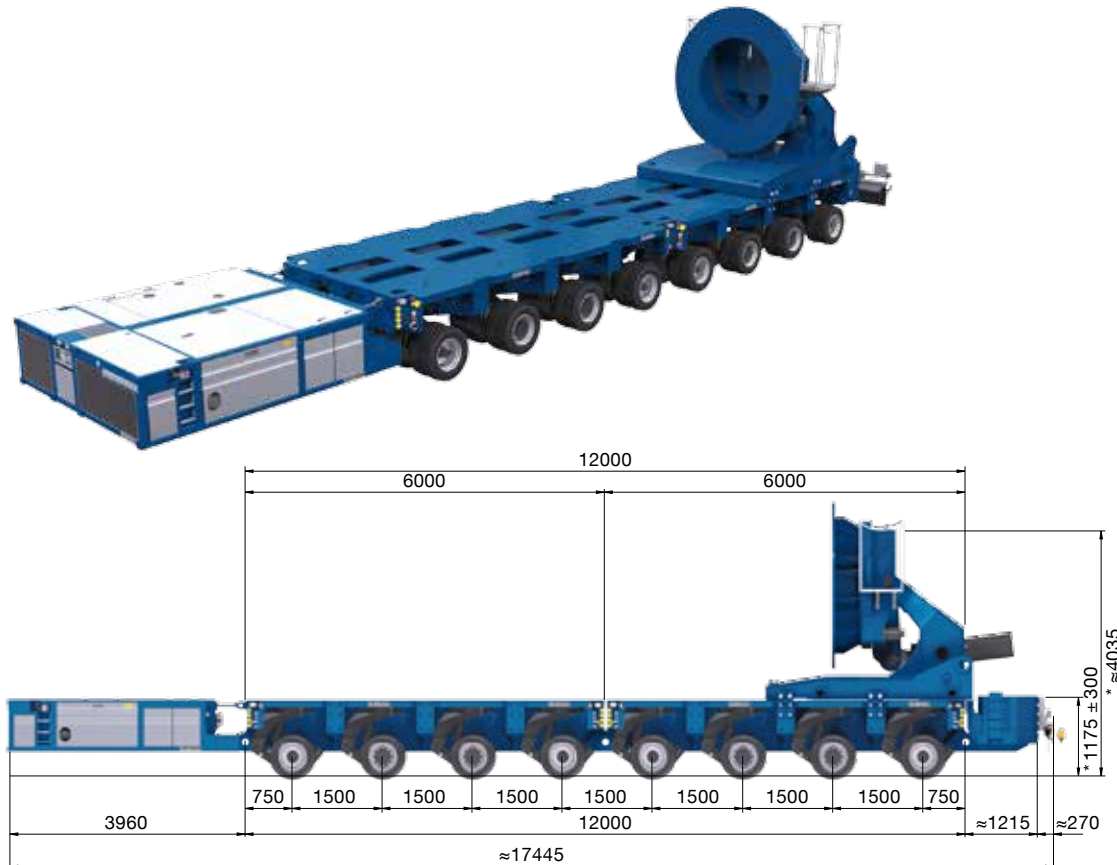

### FEATURES:

- ✓ Flexible transport device for mounting on self-propelled and trailer modules
- ✓ Ballast for a wide range of blade weights
- ✓ Interchangeable rotor blade adapters for various types of blades
- ✓ Tilt angle up to 60°
- ✓ Unlimited blade pitch
- ✓ Craneless loading and unloading possible
- ✓ Maximum efficiency
- ✓ Lateral pivoting option available

### TECHNICAL DATA:

- Deadweight: 13,500 kg
- Payload moment: 300 mt
- Tilt angle: 60°
- Pitch angle: 360°
- Rotor blade adapter for diameters of 2.1 and 2.8 m



\* loaded







# OUR TOOLS FOR QUICK AND EASY TRANSPORT ENGINEERING

easyVERSION

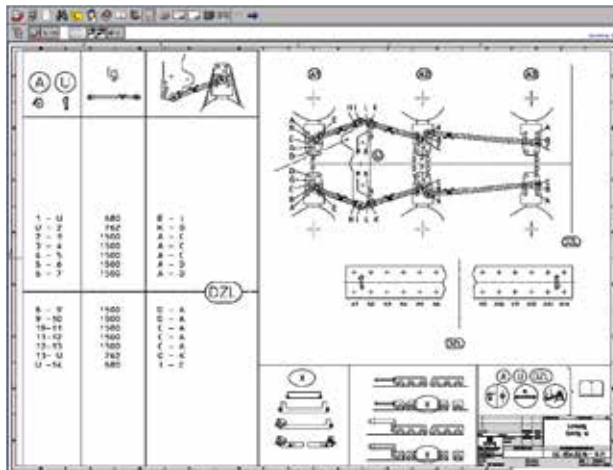

easyTRACK

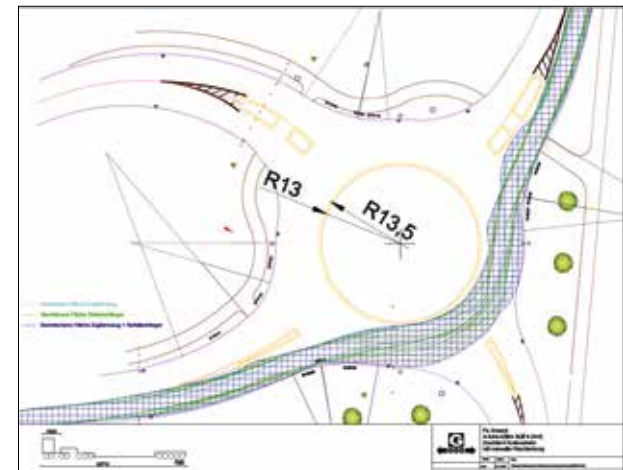

easyLOAD



# NO PROBLEM!

## SERVICE

- 24-hour emergency service
- Worldwide service partner network

## SPARE PARTS

- Fast availability
- Global distribution
- Electronic online spare parts catalog

## TRANSPORT ENGINEERING

- Operations planning software
- Route analysis
- Escort services and service engineering

## REPAIRS

- Maintenance and repair work
- Vehicle overhauls
- Mobile workshop
- Temporary replacement vehicles
- In-house repair shop
- Over 70 service points in Europe

## TRAINING ON-SITE OR AT OUR TRAINING FACILITY

- For vehicle operators
- For maintenance staff
- For load security



## SERVICE ADVANTAGES

- ✓ 24-hour service
- ✓ Worldwide service organization
- ✓ Worldwide parts supply
- ✓ Technical support and operations consulting
- ✓ Training on-site or at our training facility

**GOLDHOFER AKTIENGESELLSCHAFT**

Donaustraße 95, 87700 Memmingen/Germany  
Phone: +49 8331 15-0, Fax: +49 8331 15-239  
Web: [www.goldhofer.de](http://www.goldhofer.de)  
E-mail: [info@goldhofer.de](mailto:info@goldhofer.de)

**VERKAUF | SALES**

**Transport Technology**  
Phone Trailer/Semitrailer: +49 8331 15-341  
Phone Modular Trailer: +49 8331 15-342  
E-mail: [sales@goldhofer.de](mailto:sales@goldhofer.de)

**SERVICE | SERVICE  
ERSATZTEILE | SPARE PARTS**

**Transport Technology**  
Phone: +49 8331 15-400  
Fax: +49 8331 15-247  
E-mail: [service@goldhofer.de](mailto:service@goldhofer.de)